

RA™ & Failsafe EF™



Features

RA™ and EF™ uses the rubber profile in shear and compression, obtaining good vertical flexibility with the advantage of horizontal stability.

For normal speeds of approx. 1500 rpm, the RA™ and EF™ type provides a degree of isolation of 75-85%. For better isolation, the alternative RAEM™ or M™ can be chosen.

Its unique construction and the latest production methods make Novibra® type RA™ and EF™ a high performance mounting having a number of advantages:

- ▼ Rubber features are utilised effectively combining compression and shear.
- ▼ Wide load rating options, 40-2100 kg.
- ▼ Corrosion protected to cope with arduous environments on land or marine applications (Fe/Zn8C as per ISO 2081).
- ▼ Fitted as standard with an integral fail-safe design device with resilient stop, making RA and EF ideal for use in mobile applications. The RA™/EF™ mounts can accommodate occasional shock loads. The mount will withstand shock loads up to 2 g without plastic deformation.
- ▼ Clear and durable product marking so that mountings can be identified even after several years in operation.
- ▼ Domed shape cover to protect against oil contamination.

Novibra® type RA™ Metalastik® type Failsafe EF™

For effective isolation of vibration and noise on machines with rotating movements, the product can be applied to:

- ▼ Pumps
- ▼ Fans
- ▼ Converters
- ▼ Compressors
- ▼ Combustion engines
- ▼ Industrial and Marine gensets
- ▼ Generators

Also suitable for use with presses, punches and other work shop machines.

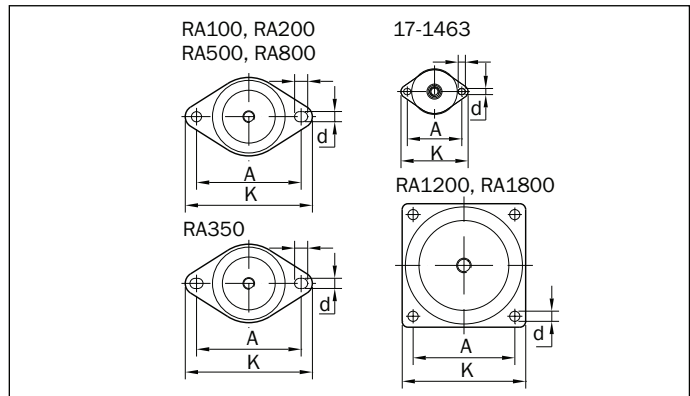
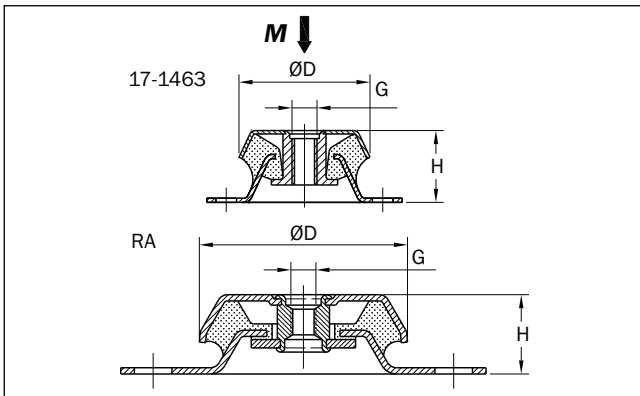

Type	Part no.		Dimensions in mm							M-Max (Kg)		Weight (Kg)	
	40°IRH	60°IRH	D	A	H	K	d	L	G	40°IRH	60°IRH		
17-1463-35		10-00503									55		0,22
17-1463-45		10-00504	65	76,2	35	94	8,5	10	M12		80		0,22
17-1463-60		10-00505									170		0,22
17-1463-70		10-00506									240		0,22
RA100/M10	10-00106	10-00107	79	110	30	130	9	12	M10	105	240		0,33
RA100/M12	10-00166	10-00167	79	110	30	130	9	12	M12	105	240		0,33
RA200/M10	10-00110	10-00111	94	124	35	150	10	15	M10	180	280		0,47
RA200/M12	10-00165	10-00091	94	124	35	150	10	15	M12	180	280		0,47
RA350/M12	10-00172	10-00173	101	140-148	38	175	14	18	M12	250	450		0,74
RA350/M16	10-00112	10-00113	101	140-148	38	175	14	18	M16	250	450		0,74
RA500	10-00116	10-00117	123	158	42	192	14	18	M16	450	700		1,02
RA800	10-00118	10-00119	144	182	46	216	14	18	M16	750	1300		1,59
RA1200	10-00154	10-00155	161	140	58	170	14		M20	900	1600		2,19
RA1800	10-00156	10-00157	181	160	66,5	190	14		M20	1300	2100		2,33

RA™ & Failsafe EF™

Note: The natural frequencies and degrees of isolation are based on dynamic characteristics of the mountings.

Load per mounting (kg)

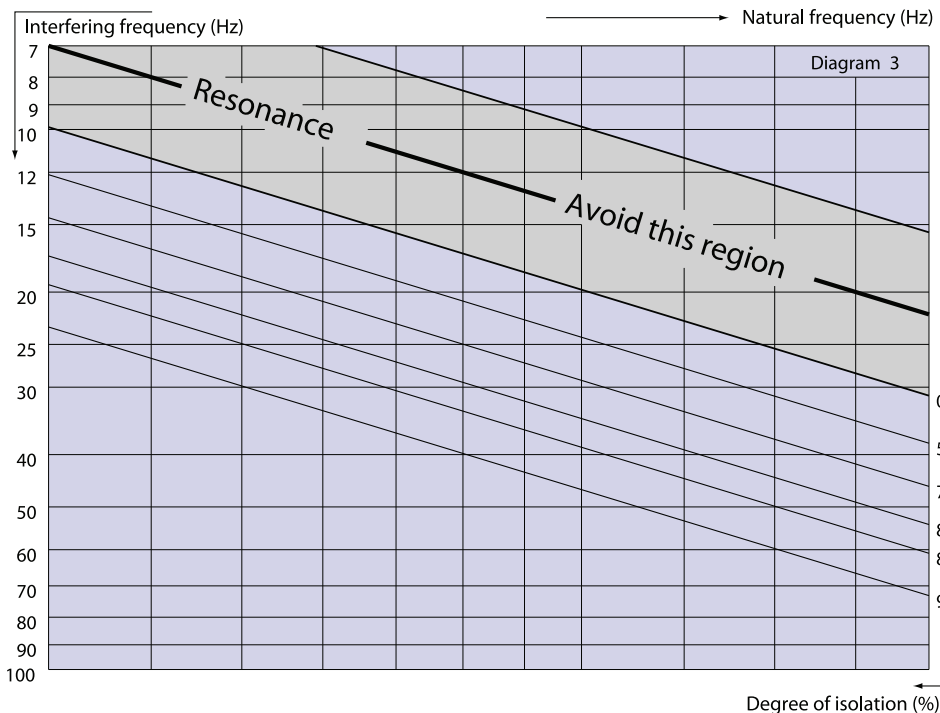
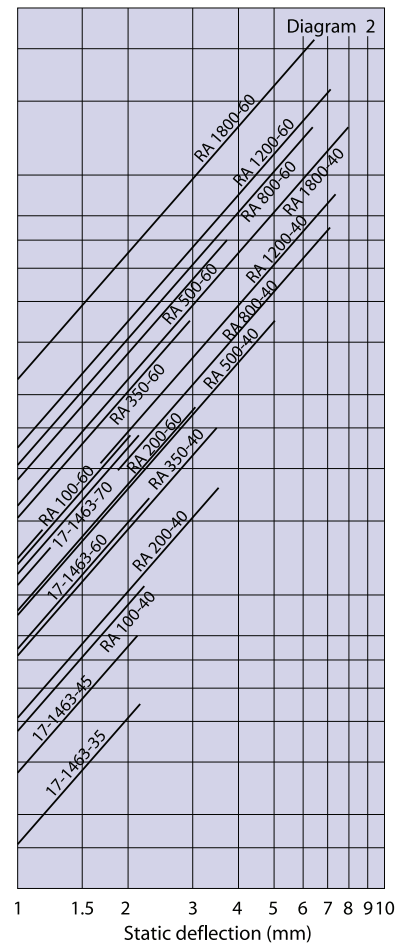
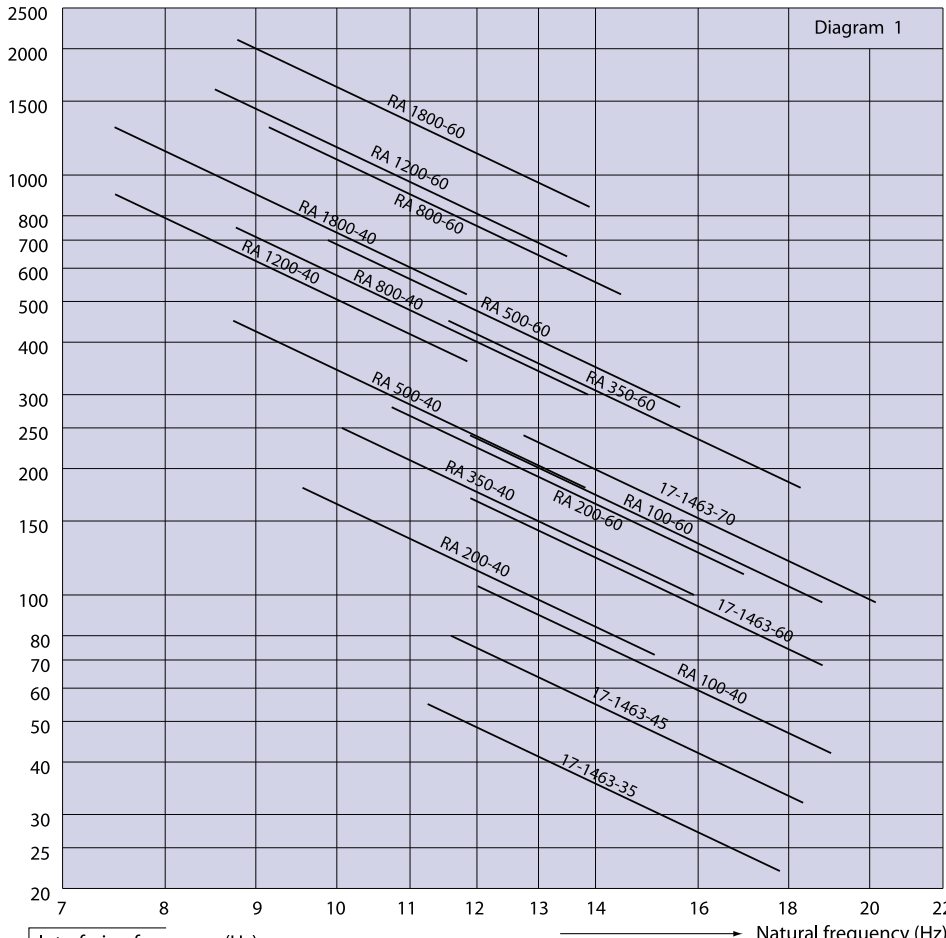

To select correct mounting, following data are needed:

- 1) Load per mounting (kg)
- 2) Interfering frequency (Hz)
(Hz = rpm / 60)

Select correct load line in diagram 1 and correct interference line in diagram 3. The load line intersects with required type of mounting. Connect this intersection point vertically down to the interference line in diagram 3. Here, on the sloping curve, the isolation degree is indicated. For static deflection, see diagram 2.

