



Features

SIM™ is a mounting for mobile applications. The strong metal parts and the soft vertical stiffness combined with high stiffness in the longitudinal direction makes it suitable for suspension of marine engines both with and without thrust bearing.

Its unique construction and the latest production methods make Novibra type SIM a high performance mounting having a number of advantages.

- ▼ Low vertical natural frequency 8-9 Hz combined with high longitudinal stiffness, ratio approx $k_l/k_v=3.5-5.5$.
- ▼ Special designed stronger bottom plate and top cover to withstand high shock loads from tough mobile applications.
- ▼ Load range from 50-580kg.
- ▼ Fitted as standard with a shock proof device (up to 5g) with resilient stop.
- ▼ Corrosion protected to cope with arduous environments with treatment Fe/Zn8C as per ISO 2081.
- ▼ SIM can be delivered with two types of height adjusters, one standard type HA and HAD for higher load requirements.
- ▼ Clear and durable product marking. Mountings can be identified after several years in operation.
- ▼ Domed shape top cover to protect against oil contamination.

Novibra® type SIM™

Type SIM™ is used for vibration isolation of small to medium sized machines:

- ▼ Fans
- ▼ Pumps
- ▼ Engines
- ▼ Compressors
- ▼ Measurement equipment
- ▼ Marine propulsion engines
- ▼ Refrigeration and air-conditioning

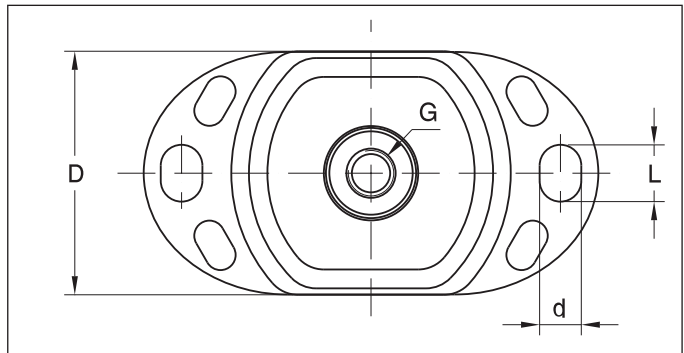
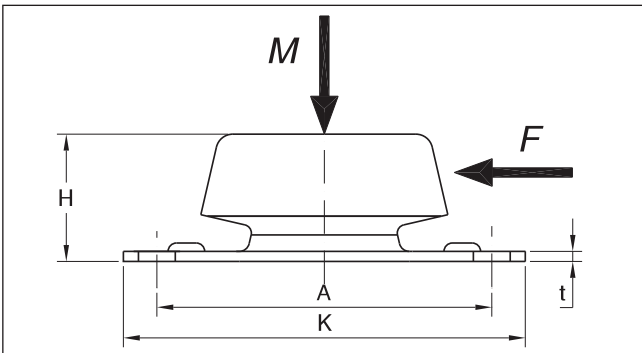

Type	IRH	Part no.	Dimensions in mm							Max Load M ((Kg)	Max Longitudinal Force F(N)	Weight (Kg)	
			D	A	K	H	d	L	t				
SIM 100	40° IRH	10-00043	64	100	120	38	11	15	3	M12	50	750	0,35
	50° IRH	10-00046	64	100	120	38	11	15	3	M12	60	1000	0,35
	60° IRH	10-00044	64	100	120	38	11	15	3	M12	100	1400	0,35
	70° IRH	10-00045	64	100	120	38	11	15	3	M12	130	2000	0,35
SIM 200	40° IRH	10-00047	75	140	175	50	13	20	4	M16	100	2000	0,75
	50° IRH	10-00050	75	140	175	50	13	20	4	M16	150	3000	0,75
	60° IRH	10-00048	75	140	175	50	13	20	4	M16	230	4500	0,75
	70° IRH	10-00049	75	140	175	50	13	20	4	M16	310	6000	0,75
SIM 300	40° IRH	10-00051	112	182	216	70	18	26	5	M20	220	5000	2,03
	50° IRH	10-00054	112	182	216	70	18	26	5	M20	300	6500	2,03
	60° IRH	10-00052	112	182	216	70	18	26	5	M20	460	9000	2,03
	70° IRH	10-00053	112	182	216	70	18	26	5	M20	580	12000	2,03

Note: The natural frequencies and degrees of isolation are based on dynamic characteristics of the mountings.

Load per mounting (kg)

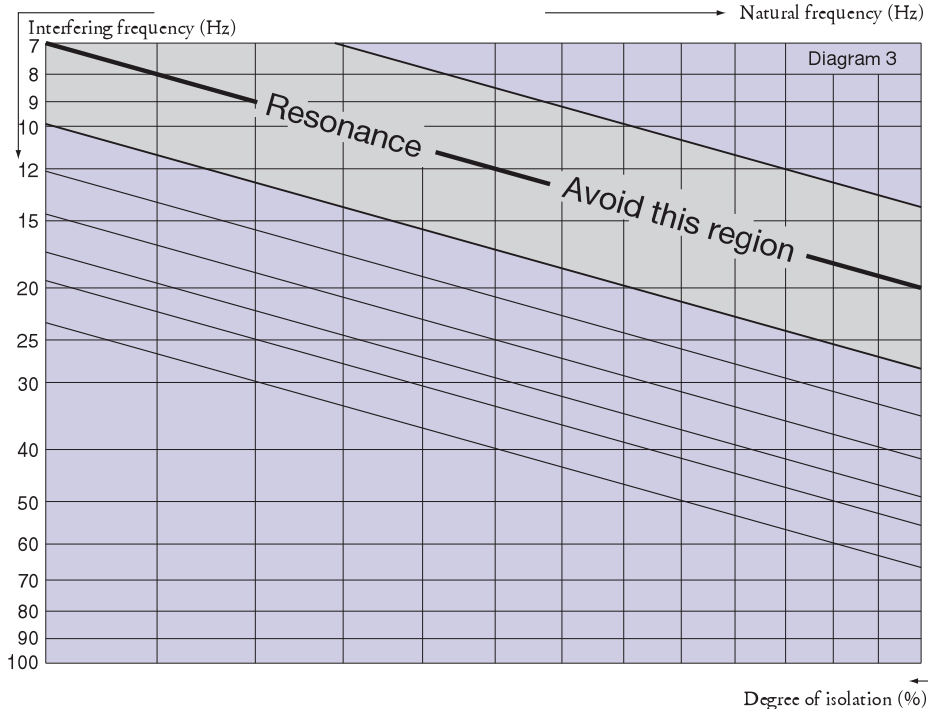
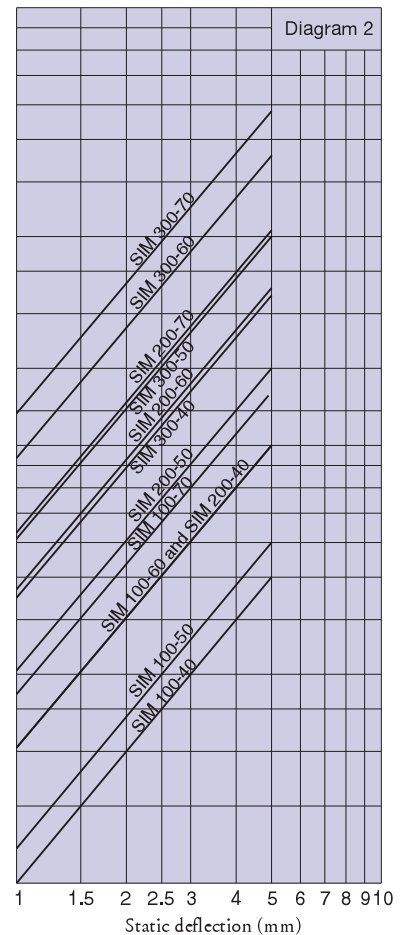
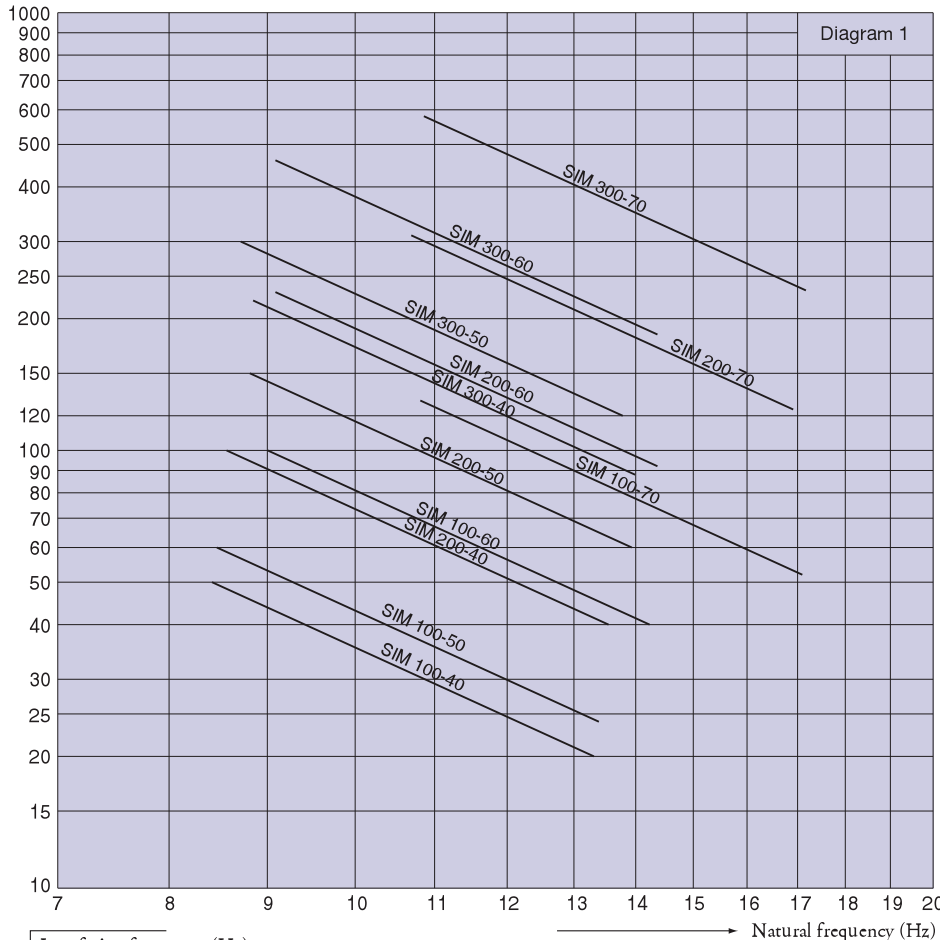

To select correct mounting, following data are needed:

- 1) Load per mounting (kg)
- 2) Interfering frequency (Hz)

(Hz = rpm / 60)

Select correct load line in diagram 1 and correct interference line in diagram 3. The load line intersects with required type of mounting.

Connect this intersection point vertically down to the interference line in diagram 3. Here, on the sloping curve, the isolation degree is indicated.

For static deflection, see diagram 2.

